

TECHNICAL DATA

REFUSE COMPACTOR

BC 972 RB-2, BC 1172 RB-2

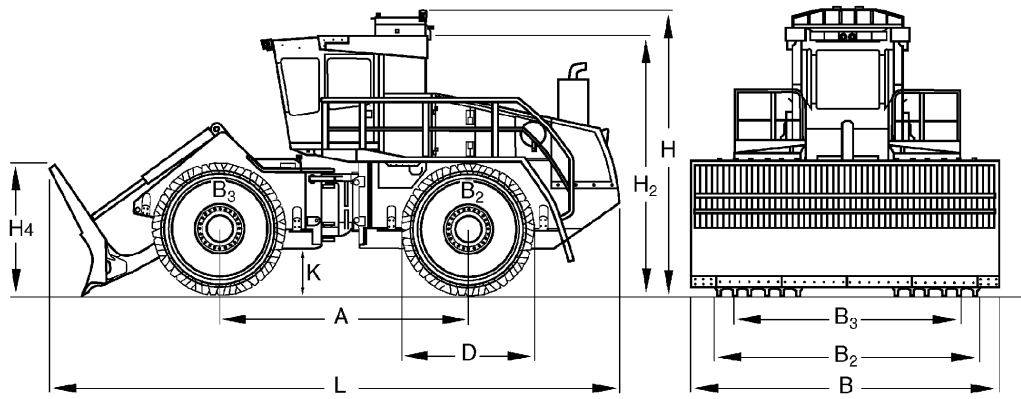



Dimensions in mm

| | A | B | B2 | B3 | D | H | H2 | H4 | K | L |
|---------------------|----------|----------|-----------|-----------|----------|----------|-----------|-----------|----------|----------|
| BC 972 RB-2 | 4100 | 5200 | 4500 | 4260 | 2200 | 4845 | 4400 | 2225 | 765 | 9425 |
| BC 1172 RB-2 | 4100 | 5200 | 4500 | 4260 | 2200 | 4845 | 4400 | 2225 | 765 | 9425 |

Shipping dimensions in m3

| | |
|---------------------|---------|
| BC 972 RB-2 | 215,644 |
| BC 1172 RB-2 | 215,644 |

Technical Data**BOMAG
BC 972 RB-2****BOMAG
BC 1172 RB-2****Weights**

| | | | |
|------------------------------------|----|---------------|---------------|
| Grossweight | kg | 47.300 | 55.300 |
| Operating weight CECE | kg | 46.500 | 54.500 |
| Axle load, front / rear CECE | kg | 22.850/23.650 | 26.850/27.650 |

Dimensions

| | | | |
|---------------------|----|-------|-------|
| Rear overhang | mm | 2.535 | 2.535 |
|---------------------|----|-------|-------|

Driving Characteristics

| | | | |
|---|------|---------|---------|
| Speed (1), forward | km/h | 0- 3,0 | 0- 3,0 |
| Speed (1), reverse | km/h | 0- 3,0 | 0- 3,0 |
| Speed (2), forward | km/h | 0- 5,0 | 0- 5,0 |
| Speed (2), reverse | km/h | 0- 5,0 | 0- 5,0 |
| Speed (3), forward | km/h | 0- 12,0 | 0- 12,0 |
| Speed (3), reverse | km/h | 0- 12,0 | 0- 12,0 |
| Max. gradeability (dep. on soil con.) | % | 100 | 100 |
| Max. pushing force | kN | 502 | 588 |

Drive

| | | | |
|------------------------------|-------|----------|----------|
| Engine manufacturer | | Deutz | Deutz |
| Type | | TCD 2015 | TCD 2015 |
| Cooling | | Liquid | Liquid |
| Number of cylinders | | 8 | 8 |
| Performance ISO 9249 | kW | 400,0 | 440,0 |
| Performance SAE J 1349 | hp | 536,0 | 590,0 |
| Speed | min-1 | 1.900 | 1.900 |
| Travel system | | hydrost. | hydrost. |
| Operating voltage | V | 24 | 24 |

Compaction Wheels

| | | | |
|--------------------------------------|----|-------|-------|
| Width, front | mm | 1.400 | 1.400 |
| Width, rear | mm | 1.400 | 1.400 |
| Outer diameter (front) | mm | 2.200 | 2.200 |
| Outer diameter (rear) | mm | 2.200 | 2.200 |
| Number of teeth/cutters, front | | 72 | 72 |
| Number of teeth/cutters, rear | | 72 | 72 |
| Compaction coverage per side | mm | 1.520 | 1.520 |

Brakes

| | | | |
|---------------------|--|-----------|-----------|
| Service brake | | hydrost. | hydrost. |
| Parking brake | | hydromec. | hydromec. |

Steering

| | | | |
|--|------|--------------|--------------|
| Steering system | | oscil.artic. | oscil.artic. |
| Steering method | | hydraulic | hydraulic |
| Track radius, inner | mm | 3.050 | 3.050 |
| Steering / oscillating angle +/- | grad | 40/15 | 40/15 |

Dozer Blade

| | | | |
|---|----|-------|-------|
| Height adjustment over ground level | mm | 1.375 | 1.375 |
| Height adjustment below ground level | mm | 50 | 50 |
| Dozer blade capacity acc. to SAE J 1265 | m3 | 15,8 | 15,8 |

Capacities

| | | | |
|---------------------|---|---------|---------|
| Fuel | l | 1.000,0 | 1.000,0 |
| Engine oil | l | 47,0 | 47,0 |
| Hydraulic oil | l | 590,0 | 590,0 |

Technical modifications reserved. Machines may be shown with options.

Standard Equipment

Optional Equipment

- Premium compaction wheels with highly wear resistant teeth
- Reversing monitor
- Pre start cabin heating
- Fire extinguisher
- Special painting
- Environmentally compliant hydraulic oil
- Protective ventilation system (Pre-installation)
- Lockable hood lock (anti-theft protection)
- Tool kit
- Reversible fan
- Semi-U-Blade 5250mm
- Automatic heating - air conditioning



PRE 570 80 010

050216 Sa

BOMAG
Hellerwald
D-56154 Boppard
P.O. Box 5162
Tel. (0)6742 - 1000
Fax (0)6742 - 3090

